



V CHAMBER

PATENTED "NO WELD"

JOIST-TO-PANEL CONNECTOR

SIMPLE • SAFE • SECURE™



SIMPLE INSTALLATION

- > Eliminates field welding
- > Cuts erection time - connection made remotely
- > Reduces labor and equipment

SAFETY ASSURED

- > Tested to 75 KIPs ultimate
- > Eliminates workers on lifts

SECURE CONNECTION

- > Fast, reliable inspection
- > Failsafe mechanical connection

As structural engineers of building systems, we have concerns about the quality of field welding on critical structural elements. Since field welding is not required for V connections, the issue is eliminated. I personally observed the load test for the V Joist Hanger and was impressed with the rousstness of the elements.

- Jeff Needham, President, Needham/DBS

Weldless Innovative Connection

Developed in response to requests from steel erectors and concrete contractors, the *PATENTED* AdvanConn® V Chamber provides a secure mechanical connection for the erection of structural steel to concrete without the expense and uncertainty of field welding.

The interlocking chamber and bearing seat engage remotely, eliminating the need to manually connect the steel to the concrete. The result is reduced labor and equipment cost, as well as increased job site safety.

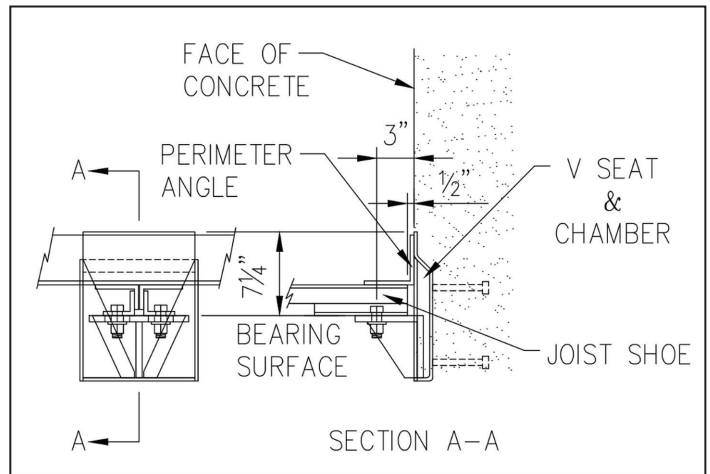

FOR MORE INFORMATION



(614) 382-0564
theadvanconn.com

